



APV Homogenizer

Rannie 55 /Gaulin 55

Introduction

The Rannie 55 / Gaulin 55 homogenizer, a positive displacement triplex, reciprocating plunger pump, is fitted with an application-specific homogenizing valve assembly: single-stage with hydraulic actuation. As a high-pressure pump, this unit can be fitted with a relief valve.



Rannie three-piece valve housing

The Rannie 55 / Gaulin 55 homogenizer incorporates a durable slow-speed power end that reduces vibration and noise. Easy access to the hydraulic actuation system, lubrication oil and other auxiliary systems simplifies maintenance saving time and money. Liquid end options include a three-piece valve housing (Rannie) and a mono-block design (Gaulin). As a standard the homogenizer is equipped with the type of homogenizing valve best suited for your process.

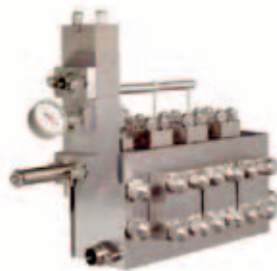

Gaulin mono-block design

Design features of both the Rannie and Gaulin simplify routine maintenance. Materials for plungers, packings, pump valves, valve seats and seals are custom-

selected for your application. SPX engineers will work with you to optimise the configuration for your specific application.

Standard Options

- Two-stage hydraulic valve actuation (HVA)
- Single-stage automatic hydraulic system (AHS)
- Two-stage automatic hydraulic system (AHS)
- Pulsation dampener(s) on inlet and outlet
- Aseptic cylinder design
- High-pressure outlet
- Inlet pressure gauge
- Plunger lubrication control package
- Micro-Gap homogenizing valve
- Tungsten carbide homogenizing valve
- Square plunger seals and ceramic plungers (Rannie valve housing only)
- External cooling fan/main motor
- Motor starter
- Control cabinet, stainless steel
- Thermostat/oil temperature

Special Options

- Acid-proof cylinder (Gaulin valve housing only)
- Ceramic plungers with U- or V-rings
- Explosion-proof design
- Electropolished wettables
- High-temperature design
- Flow switch - power end cooling

Rannie/Three-Piece Valve Housing
Poppet and Ball Type Valves

Type	US max. cap./max. press.		Metric max.cap./max. press.	
	GPH	PSI	LPH	BAR
70.95	3300	2175	12500	150
60.95	2380	2900	9000	200
54.95	1980	3625	7500	250
50.95	1660	4300	6300	300
42.95	1160	5800	4400	400
35.95	770	8700	2900	600
30.95	555	11600	2100	800
25.95	370	14500	1400	1000
22.95	210	17400	800	1200
20.95	160	21750	600	1500

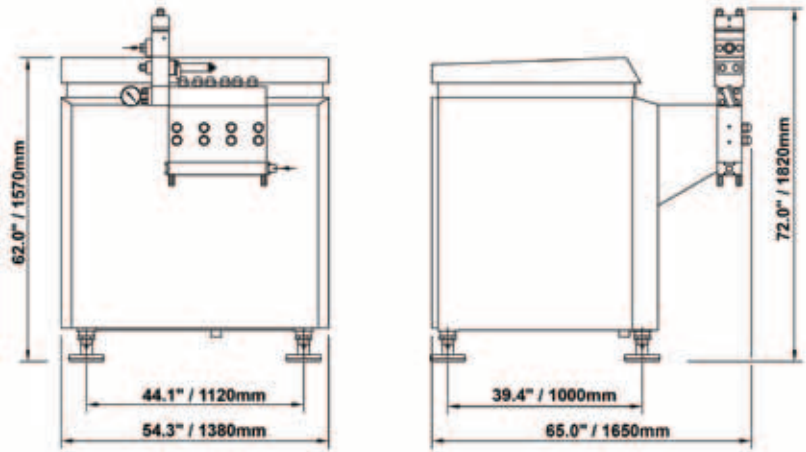

Gaulin/Mono-Block Design

Type	US max. cap./max. press.		Metric max.cap./max. press.	
	GPH	PSI	LPH	BAR
Poppet type valves				
1.5	4230	1500	16000	100
2.5	2775	2500	10500	170
3.0	2380	3000	9000	210
4.3	1640	4300	6200	300
5.8	1160	5800	4400	400
Ball type valves				
1.5	3620	1500	13700	100
2.5	2380	2500	9000	170
3.0	2035	3000	7700	210
4.3	1400	4300	5300	300
5.8	990	5800	3750	400
8.7	685	8700	2600	600

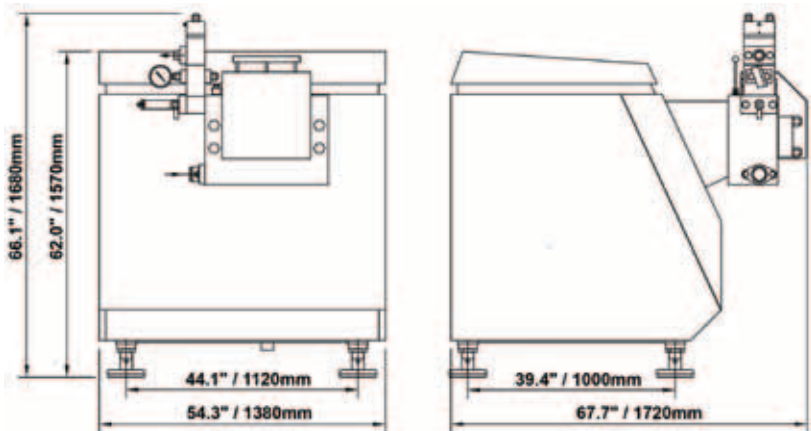

Dimensions (Single Stage)

Dimensions packed in a crate LxWxH (in.)	Dimensions packed in a crate LxWxH (cm)	Cubic measure m ³	Gross weight in a crate incl. motor
75.6 x 66 x 84.4	189 x 165 x 211	6.6	6,613 lb./3,000 kg

SPX Flow Technology
Phone: (888) 278-4321
Email: answers.us@apv.com
www.apv.com
www.spxft.com

For more information about our worldwide locations, approvals, certifications, and local representatives, please visit www.apv.com.

SPX Corporation reserves the right to incorporate our latest design and material changes without notice or obligation. Design features, materials of construction and dimensional data, as described in this bulletin, are provided for your information only and should not be relied upon unless confirmed in writing.

Issued: 03/2011 3024-04-03-2011-GB

Copyright © 2002 SPX Corporation

